

# Highly efficient fans with highly efficient drive technology

Brushless DC

AIRTREND Ltd.  
Predstavništvo u Beogradu  
Kumanovska 14  
11000 Beograd  
Tel: 011 3836886, 3085740  
Faks: 011 3444113  
e-mail: [gobrid@eunet.rs](mailto:gobrid@eunet.rs)  
web: [www.airtrend.rs](http://www.airtrend.rs)

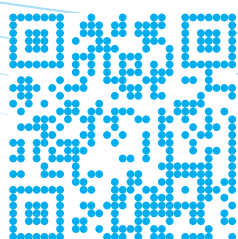

**NICOTRA** | **Gebhardt**

fan|tastic solutions

# The entire range with new drive

The entire product line of direct driven fans by Nicotra Gebhardt is now available with the particularly energy efficient brushless DC technology. These innovative motors achieve the highest efficiency and therefore cost less to operate than traditional AC motors in every application.

## Fit for the future with brushless DCs

The EU's ErP Directive prescribes minimum levels of efficiency for electric motors. These levels of efficiency will be steadily increased in the coming years. Motors with brushless DC drives already exceed the requirements that will become compulsory in 2015 and 2017.

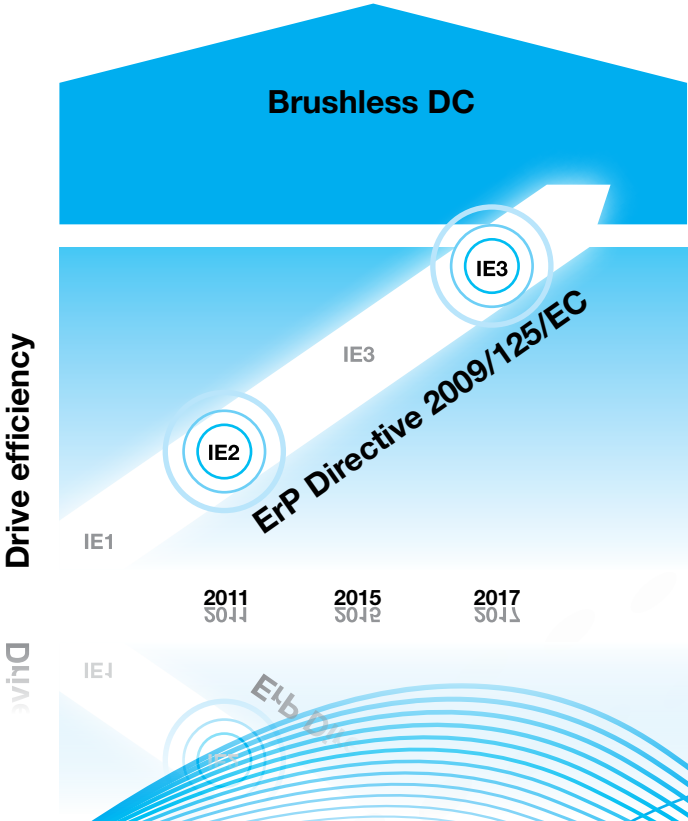

# The right brushless DC motor for every centrifugal fan

## RLMEVO

Direct Driven Centrifugal Fan  
Plug Fan

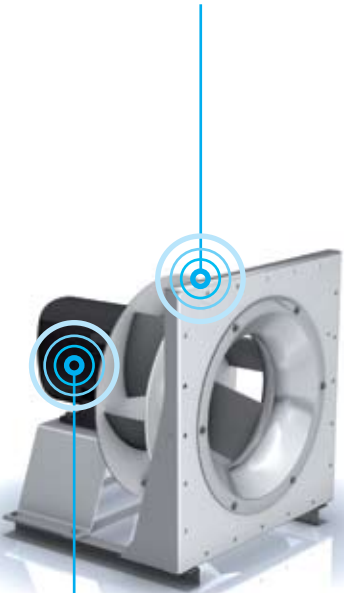

with  
brushless DC internal rotor motor  
with integrated control electronics



or alternatively with  
brushless DC internal rotor motor  
+ external control electronics



\* Picture credits: Danfoss

## RLEVO

Direct Driven Centrifugal Fan  
Plug Fan



with  
brushless DC external rotor motor  
with integrated control electronics



## DDMB

Direct Driven Centrifugal Fan



with  
brushless DC external rotor motor  
+ external control electronics

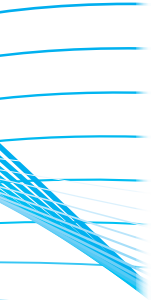

## RZP

Direct Driven Centrifugal Fan

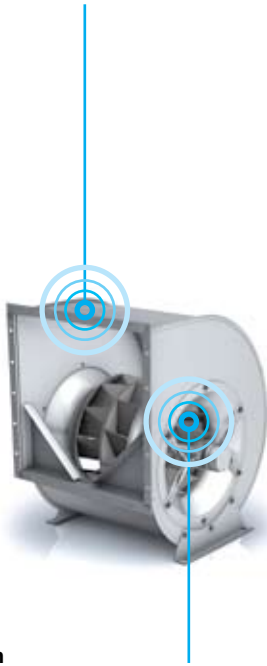

with  
**brushless DC external rotor motor**  
+ external control electronics



## RZM

Direct Driven Centrifugal Fan

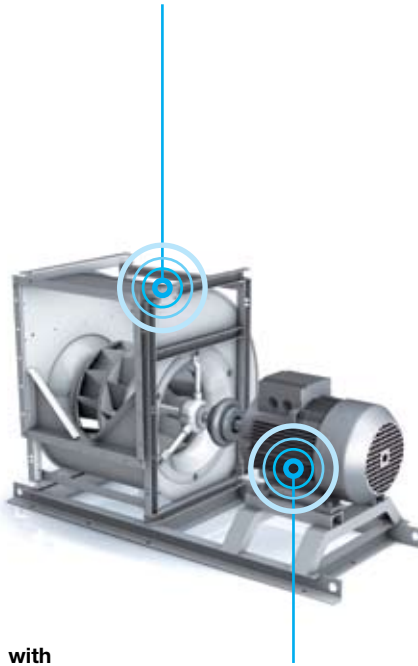

with  
**brushless DC internal rotor motor**  
with integrated control electronics



or alternatively with  
**brushless DC internal rotor motor**  
+ external control electronics



## RDA

Roof Extract Fan

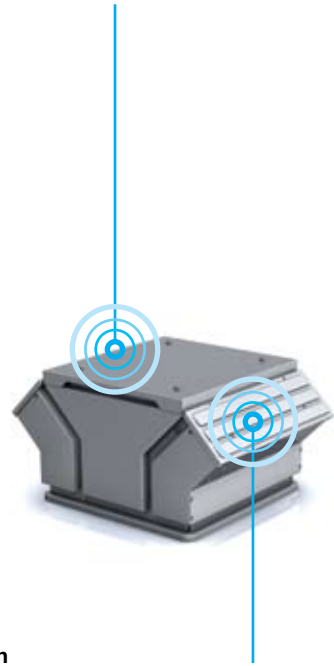

with  
**brushless DC external rotor motor**  
+ built-in external control electronics



# Why brushless DCs are effective



**01** \_

## Higher efficiency

Brushless DC motors achieve significantly higher efficiencies than AC motors in all load ranges.

Up to 50 % energy can be saved in partial loads.

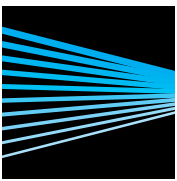

**02** \_

## Lower losses

Brushless DC motors work without slip. This results in significantly lower losses than when using induction motors.

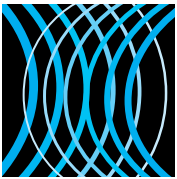

**03** \_

## Electrical energy is fully converted into torque

The supplied electrical energy is fully converted into available torque through the use of permanent magnets.

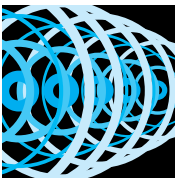

**04** \_

## Harmonised control electronics

An electronic control takes over the speed control and regulation. The motor and the electronic control form one harmonised,

coherent unit.



**05** \_

## Higher power densities

The power densities of brushless DC motors are markedly higher than that of AC motors.

This is why the size of the unit is smaller with the same output.



**06** \_

## Improves system efficiency of fans

Due to their high efficiency, drives with brushless DC motors lastingly improve system efficiencies of fans and in this way assist in meeting the

ever more stringent legal requirements.